

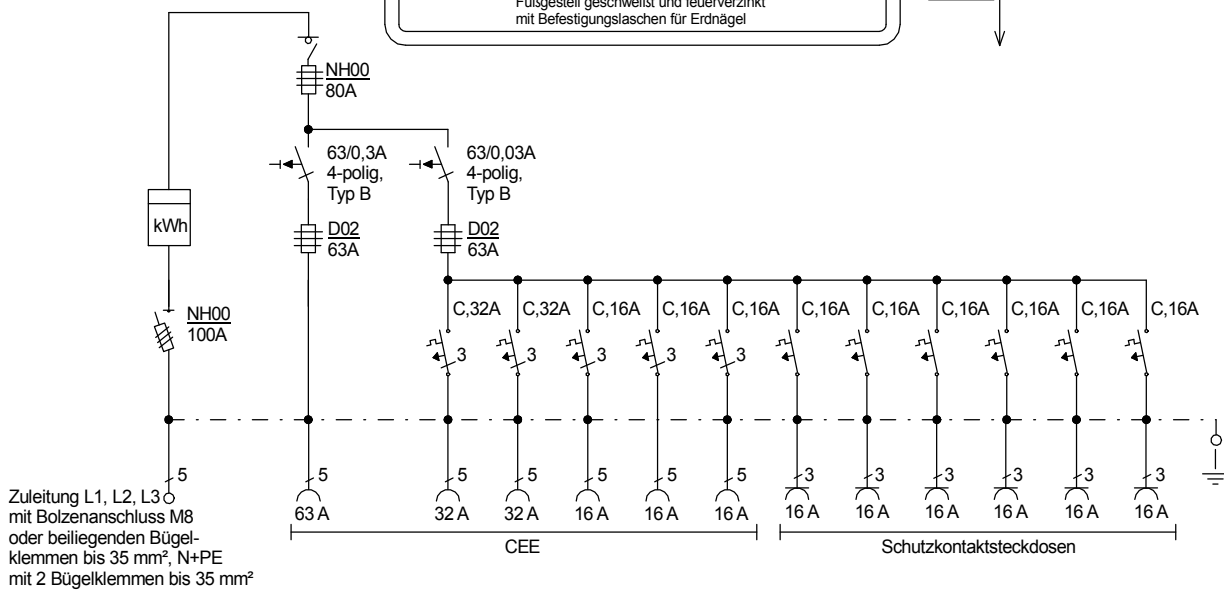

STEIDELE STROMVERTEILER

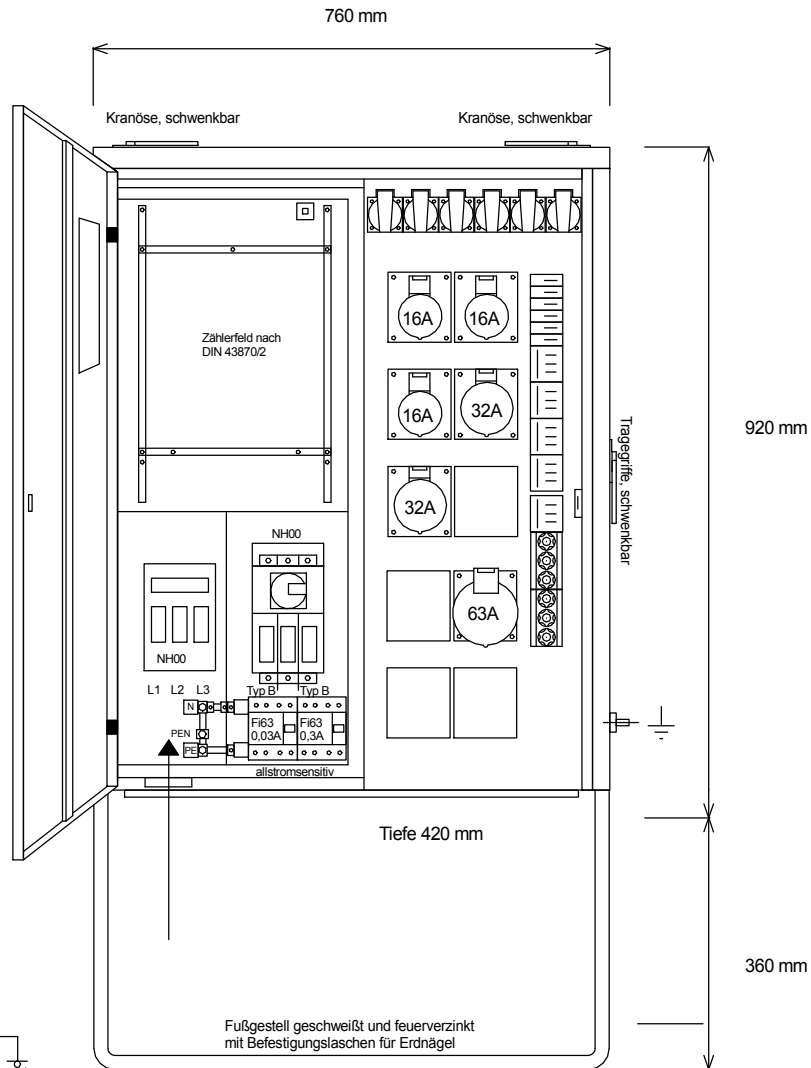

Entsprechend dem Entwurf der neuen DIN VDE 0100-704, Dezember 2016

Typ: AV 80.2/321-6

Best.Nr. 1680

Anschluss-Verteiler nach EN 61439-4

gezeichnet am/von:

Leistung 55 kVA, Gewicht ca. 65 kg, Gehäuse 13.7

28.03.2017 / Uffinger